

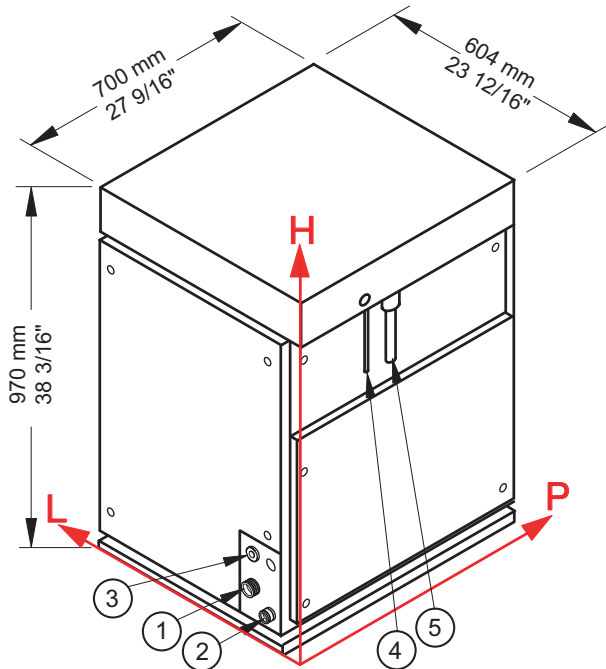

Ice Scales

FHESM1500S Split CO₂

Modular ice maker - Scale system
Daily production up to 1520 kg



► Working conditions

- Location: **Indoor**

	Min	Max
Ambient temperature	+10° C / +50° F	+43° C / 110° F
Water temperature	+3° C / +37° F	+32° C / +90° F
Voltage	-10%	+10%
Water inlet pressure	1bar (14 psi)	6bar (84 psi)

► Connections

- ① Water inlet
- ② Water outlet
- ③ Electrical connection
- ④ Refrigerant feeding pipe
- ⑤ Outlet pipe of gaseous refrigerant

► Technical information

Production in 24h	1520 kg / 3351 lbs
Refrigerant	CO ₂ (R744)
Refrigerant capacity	8550 W (evap. temp. -23° C)
PS suction line	580 PSI - 40bar
Water consumption	1 l/kg - 12,0 gal/100 lbs
Standard voltage	220-240 V ~ 50 Hz
Average power consumption	180 W

Sizes (L-P-H mm)	604 - 700 - 970
(L-P-H in)	23 12/16 - 27 9/16 - 38 3/16
Sizes with pack (L-P-H mm)	655 - 785 - 1145
(L-P-H in)	25 13/16 - 30 14/16 - 45 1/16
Net weight	144 kg / 317 lbs
Gross weight	160 kg / 353 lbs
Finishing	AISI 304 stainless steel, scotch brite

All the technical information need to be considered at the following conditions:
Refrigerant capacity 8550 W (evap. temp. -23° C)
Water temperature +15° C
Average power consumption at +43° C (standard voltage)

Models and specifications are subject to change without notice

Rev. 04 - Issued Settembre 2019

